

■ 2048 x 1536

■ 107 fps

Fusion Series 

**GigE**  
VISION

## FS-3200T-10GE-NNC

3.2 megapixel 3-CMOS multispectral



- **Multispectral prism camera with three 1/1.8" CMOS imagers**
- **Simultaneously captures images in visible color and two near-IR wavebands**
- **Prism technology insures all three images share the same optical path**
- **3.45 x 3.45  $\mu\text{m}$  pixel sizes with support for 1x2, 2x1, or 2x2 binning on NIR channels**
- **Up to 107 fps over high performance 10GBASE-T (10 gigabits per second) interface**
- **Backwards compatible to NBASE-T (5GBASE-T/2.5GBASE-T) and standard GigE (1000BASE-T)**
- **Single and multi-ROI modes provide higher speeds with lower processing loads**
- **8, 10, or 12-bits per channel\***
- **Supports separate or unified control of key camera parameters for each channel**
- **Excellent shock and vibration resistance**
- **GigE Vision 2.0 interface with triple-stream output**
- **C-mount lens mount**

\* Some video processing functions not available with 12-bit output

# Specifications for FS-3200T-10GE-NNC

# Fusion Series

Specifications	FS-3200T-10GE-NNC
Sensor	1/1.8" 3-CMOS global shutter (IMX252)
Active pixels	2048 (h) x 1536 (v) x 3 (Bayer / NIR / NIR)
Frame rate, full frame	107.2 frames/sec. @ 8-bit
Active area	7.07 mm (h) x 5.30 mm (v) - 8.83 mm diagonal
Pixel size	3.45 μm x 3.45 μm
System clock	74.25 MHz (for pulse generator)
Read-out modes	Full ROI (single)
	ROI (multi) Binning
	2048 (h) x 1536 (v) for each channel H: 16 to 2048 pixels in 16 pixel steps V: 8 to 1536 lines in 4 line steps Up to 64 areas can be defined. No overlap. 1x2, 2x1, 2x2 (NIR channels only)
EMVA 1288 Parameters	12-bit output format
Absolute sensitivity	4.30 p (λ = 525 nm), 8.86 p (λ = 810 nm)
Maximum SNR	39.45 dB green, 39.02 dB NIR
Traditional SNR* color	>60 dB (0 dB gain, 10-bit)
NIR	>60 dB (0 dB gain, 10-bit)
Video signal output† (Three streams)	Visible: BayerRG8, BayerRG10, BayerRG10Packed, BayerRG12, BayerRG12Packed NIR: Mono8, Mono10, Mono10Packed, Mono12, Mono12Packed
Video modes	Normal, Single ROI, Multi ROI, Sequencer (2 modes)
Gain	Manual control - master mode 0 to +24 dB R/B channels - individually -7 to +15 dB Auto gain control - off, continuous, one-push
White balance (Color channel only)	Off, 4 presets (3200K, 5000K, 6500K, 7500K), or one-push/continuous AWB (3000K to 9000K)
Gamma/LUT	0.45 to 1.0 (9 steps) or 257-point programmable LUT
Shading correction	Flat shading, color shading
Trigger input	Opto In (2), Pulse Generators (4), Software, TTL In (2), NAND Out (2), User Output (4)
Exposure modes	Timed/EPS, Trigger Width (to ∞), Auto, Reset Continuous Trigger (RCT) option.
Electronic shutter	(can be set independently for each channel) 14.73 μs to 8 sec. in 1 μs steps
Auto Level Control (ALC)	Shutter range from 100 μs, gain range from 0 dB to +24 dB. Tracking speeds and max. values adjustable.
Blemish compensation	Up to 1736 px/sensor
Operating temp. (ambient)	-5°C to +45°C (20 to 80% non-condensing)
Storage temp. (ambient)	-25°C to +60°C (20 to 80% non condensing)
Vibration	3G (20 Hz to 200 Hz, XYZ directions)
Shock	50G
Regulations	CE (EN 55032:2015, EN 55035:2017), FCC Part 15 Class B, RoHS/WEEE, KC
Power	12-pin +10V to +25V DC. 11.6 W typical @ +12 V
Lens mount	C-mount
Dimensions (H x W x L)	62 mm x 62 mm x 86.5 mm (excl. connectors)
Weight	270 g

## Ordering Information

FS-3200T-10GE-NNC	3-CMOS multispectral camera with GigE Vision
-------------------	--

\*Traditional SNR is based on random noise in a single frame, where EMVA SNR measurements consider more comprehensive noise sources and variance over time.

Europe, Middle East & Africa Phone +45 4457 8888	Asia Pacific Phone +81 45 440 0154	Americas Phone +1 312 763 6570
---	---------------------------------------	-----------------------------------

Visit our website on [www.jai.com](http://www.jai.com)

## Dimensions

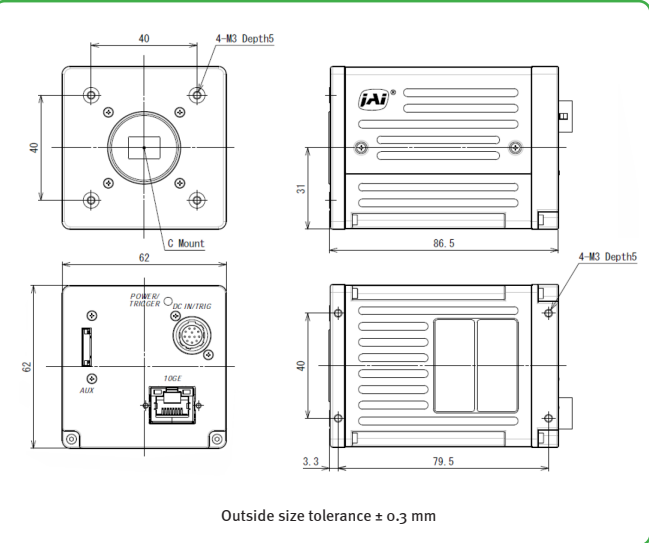

## Connector pin-out

### DC In / Trigger

HIROSE HR10A-10R-12PB(71)

Pin	Signal
1	Ground
2	DC in +10V to +25V
3	Opto In 2-
4	Opto In 2+
5	Opto In 1-
6	Opto In 1+
7	Opto Out 1-
8	Opto Out 1+
9	TTL out 1
10	TTL in 1
11	DC in +10V to +25 V
12	Ground

### GigE Vision Interface

RJ-45 with locking screws

Pin	Signal
1	TRD+ (0)
2	TRD- (0)
3	TRD+ (1)
4	TRD+ (2)
5	TRD- (2)
6	TRD- (1)
7	TRD+ (3)
8	TRD- (3)

See manual for pin-out of auxiliary connector.

## Spectral response

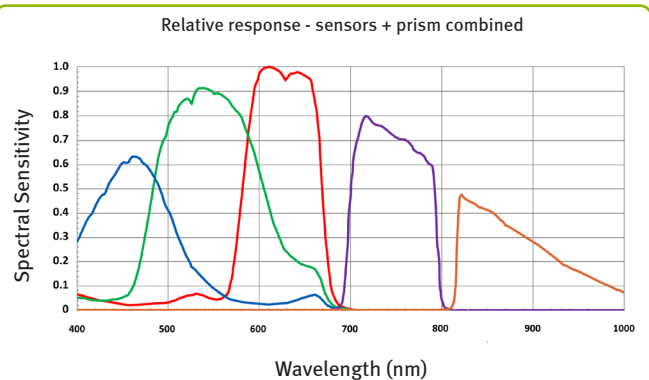

†12-bit output available in video processing bypass mode. See manual for details.

Company and product names mentioned in this datasheet are trademarks or registered trademarks of their respective owners. JAI-A-S cannot be held responsible for any technical or typographical errors and reserves the right to make changes to products and documentation without prior notice.



See the possibilities