

■ 1440 x 1080

■ 213 fps

Fusion Series 

## FSFE-1600T-10GE

1.6 megapixel CMOS multispectral

**GigE**  
VISION

### Flex-Eye base model



- **Flex-Eye configurable multispectral prism camera with three 1/2.9" CMOS imagers**
- **Customize wavebands for each sensor - minimum width of 25 nm at 5 nm increments**
- **3.45 x 3.45  $\mu\text{m}$  pixel sizes with support for 1x2, 2x1, or 2x2 binning**
- **Up to 213 fps over high performance 10GBASE-T (10 gigabits per second) interface**
- **Backwards compatible to NBASE-T (5GBASE-T/2.5GBASE-T) and standard GigE (1000BASE-T)**
- **Single and multi-ROI modes provide higher speeds with lower processing loads**
- **8, 10, or 12-bits per channel\***
- **Optional Bayer sensor can be used for waveband located within visible spectrum**
- **Supports separate or unified control of key camera parameters for each channel**
- **Excellent shock and vibration resistance**
- **GigE Vision 2.0 interface with triple-stream output**
- **C-mount lens mount**

\* Some video processing functions not available with 12-bit output

# Specifications for FSFE-1600T-10GE (Flex-Eye)

# Fusion Series

Specifications	FSFE-1600T-10GE (Flex-Eye)
Sensor	1/2.9" 3-CMOS global shutter (IMX273)
Active pixels	1440 (h) x 1080 (v) x 3 sensors
Frame rate, full frame	213 frames/sec. @ 8-bit
Active area	4.97 mm (h) x 3.73 mm (v) - 6.21 mm diagonal
Pixel size	3.45 μm x 3.45 μm
System clock	74.25 MHz (for pulse generator)
Read-out modes	Full ROI (single)
	ROI (multi) Binning
	1440 (h) x 1080 (v) for each channel H: 16 to 1440 pixels in 16 pixel steps V: 8 to 1080 lines in 4 line steps Up to 4 areas can be defined. No overlap. 1x2, 2x1, 2x2 (NIR only)
EMVA 1288 Parameters	12-bit output format
Absolute sensitivity	4.85 p (λ = 525 nm), 10.8 p (λ = 810 nm)
Maximum SNR	39.65 dB green, 39.36 dB NIR
Traditional SNR*	color >60 dB (0 dB gain, 10-bit) NIR >60 dB (0 dB gain, 10-bit)
Video signal output†	Define 3 custom wavebands between 405-1000 nm. Bayer sensor option for waveband located in visible spectrum. 8/10/12-bit mono or raw Bayer output.
Video modes	Normal, Single ROI, Multi ROI, Sequencer (2 modes)
Gain	Manual control - master mode 0 to +24 dB Auto gain control - off, continuous, one-push R/B channels - individually -7 to +15 dB
White balance (Bayer waveband only)	Off, 4 presets (3200K, 5000K, 6500K, 7500K), or one-push/continuous AWB (3000K to 9000K)
Gamma/LUT	0.45 to 1.0 (9 steps) or 257-point programmable LUT
Shading correction	Flat shading, color shading (if Bayer selected)
Trigger input	Opto In (2), Pulse Generators (4), Software, TTL In (2), NAND Out (2), User Output (4)
Exposure modes	Timed/EPS, Trigger Width (to ∞), Auto. Delayed readout option.
Electronic shutter	(can be set independently for each channel) 15.26 μs to 8 sec. in 1 μs steps
Auto Level Control (ALC)	Shutter range from 100 μs, gain range from 0 dB to +24 dB. Tracking speeds and max. values adjustable.
Blemish compensation	Up to 200 px/channel
Operating temp. (ambient)	-5°C to +45°C (20 to 80% non-condensing)
Storage temp. (ambient)	-25°C to +60°C (20 to 80% non condensing)
Vibration	3G (20 Hz to 200 Hz, XYZ directions)
Shock	50G
Regulations	CE (EN61000-6-2, EN61000-6-3) FCC Part 15 Class B, RoHS/WEEE
Power	12-pin +10V to +25V DC. 10.4 W typical @ +12 V
Lens mount	C-mount
Dimensions (H x W x L)	62 mm x 62 mm x 86.5 mm (excl. connectors)
Weight	270 g

## Dimensions

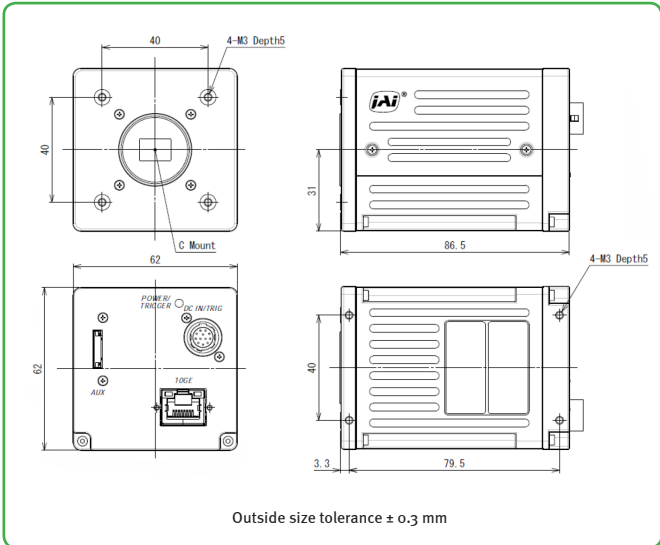

## Connector pin-out

### DC In / Trigger

HIROSE HR10A-10R-12PB(71)

Pin	Signal
1	Ground
2	DC in +10V to +25V
3	Opto In 2-
4	Opto In 2+
5	Opto In 1-
6	Opto In 1+
7	Opto Out 1-
8	Opto Out 1+
9	TTL out 1
10	TTL in 1
11	DC in +10V to +25 V
12	Ground

### GigE Vision Interface

RJ-45 with locking screws

Pin	Signal
1	TRD+ (0)
2	TRD- (0)
3	TRD+ (1)
4	TRD+ (2)
5	TRD- (2)
6	TRD- (1)
7	TRD+ (3)
8	TRD- (3)

## Spectral configuration

Number of wavebands	3, custom-defined
Spectral range	405-1000 nm
Minimum waveband width	25 nm
Minimum width increment	5 nm
Maximum visible waveband	405-680 nm (FWHM**)
Bayer sensor option	For waveband in visible spectrum

Note: not all waveband configurations are supported. Use JAI's online configurator to submit desired locations and widths for feasibility checking.

\*\*Full width of waveband at half of its maximum response (height)

## Ordering Information

FSFE-1600T-10GE	3-CMOS multispectral camera with GigE Vision
-----------------	--

\*Traditional SNR is based on random noise in a single frame, where EMVA SNR measurements consider more comprehensive noise sources and variance over time.  
 †12-bit output available in video processing bypass mode. See manual for details.

Europe, Middle East & Africa Phone +45 4457 8888	Asia Pacific Phone +81 45 440 0154	Americas Phone +1 312 763 6570
---	---------------------------------------	-----------------------------------

