

❖ **SW-16000TL-CXP4A**
 ❖ **SW-16000M-CXP4A**
 High speed CMOS line scan camera

- 3 x 16384 pixels
- 100 kHz
- 1 x 16384 pixels
- 277 kHz

Sweep Series 

CoaXPress[®]



- *Provides high speed output up to 12.5 Gbps/link (CoaXPress v2.0 standard with CXP-12 Speed)*
- *SW-16000TL-CXP4A: 3 x 16384 pixel output up to 100kHz*
- *SW-16000M-CXP4A: 1 x 16384 pixel output up to 277kHz*
- *Great sensitivity with 5.0 µm square pixels*
- *Supports backward counter and ImageOutputDelay functions via direct encoder connection*
- *Large variety of trigger options*
- *PRNU, DSNU, Master and Individual Gain mode*, Common and Individual Exposure Modes*, White Balance*, Shading, Horizontal Binning, CXPLinkSharing (DVo101 or later)*
- *LUT, Color Space Conversion*, Spatial Compensations*, Horizontal Binning*
- *Selectable output formats:*
 - RGB8, RGB10, RGB12 (SW-16000TL-CXP4A)*
 - Mono8, Mono10, Mono12 (SW-16000M-CXP4A)*
- *Excellent shock and vibration resistance*
- *Accepts power over CoaXPress interface (hardware revision B or later)*
- *M-95 lens mount*

**Supported only on SW-16000TL-CXP4A*



Specifications for SW-16000TL-CXP4A / SW-16000M-CXP4A

Sweep Series

Specifications

SW-16000TL-CXP4A / SW-16000M-CXP4A

Scanning system	SW-16000TL-CXP4A: Trilinear CMOS line scan SW-16000M-CXP4A: Monochrome CMOS line scan
Active Pixels	SW-16000TL-CXP4A: 16834 x 3 pixels (R, G, B) SW-16000M-CXP4A: 16384 x 1 pixel
Line Rate (Width = 16384)	SW-16000TL-CXP4A: Up to 100kHz, variable SW-16000M-CXP4A: Up to 277kHz, variable
Pixel size / Sensor width	5.0 μm x 5.0 μm / 81.92 mm
Trigger Inputs	2 TTL In and 1 Opto In via 12-pin, 2 TTL In via 10-pin, 1 CXP In, Software, 4 Pulse Generators, 4 Logic Blocks, 1 Encoder Trigger
Outputs	2 TTL via 12-pin, 2 TTL via 10-pin
Gain (SW-16000TL-CXP4A)	Master Mode: DigitalAll odB + 30dB, Digital RB -7.96dB + 12dB Individual Mode: DigitalGBR odB + 36dB
Gain (SW-16000M-CXP4A)	DigitalAll odB + 36dB
Gamma	0.45 to 1.0 (9 steps) or 256-point LUT
Image processing	PRNU/DSNU, black level, white balance*, shading, chromatic aberration,* spatial compensation*
Color space conversion*	RGB to HSI, RGB to XYZ (CIE), or Correction Matrix
Exposure modes	Off, Timed, and TriggerWidth
Exposure time	1 μs ~ 15.150 ms (step: 0.01 μs) at fastest line rate. Exposure time can be longer at slower line rates.
Trigger width control	1.00 μs ~ 1 sec (via 12-pin/10-pin connectors)
Interface	Micro-BNC connectors (x4) Link Configs: CXP12_X4, CXP6_X4, CXP12_X3, CXP6_X3, CXP12_X2, CXP6_X2, CXP12_X1, CXP6_X1
Lens mount	M95 (Back flange distance: 9.4 mm)
Operating temp. (ambient)	0°C to +45°C (20 to 80% non-condensing)
Storage temp. (ambient)	-25°C to +60°C (20 to 80% non condensing)
Vibration	10G (20 Hz to 200 Hz, XYZ directions)
Shock	80G
Regulations	CE (EN55032, EN55035) FCC Part 15 Subpart A, RoHS/WEEE, KC
Power	12-pin: 12V ~ 24V PoCXP: DC +18.5V ~ +26V
Consumption	12-pin: 22.0W (typical) @ DC12V, Max 26.0W **PoCXP: Max 26.0 W
Dimensions (H x W x D) (including heatsink)	TL: 187 mm x 115 mm x 78.8 mm Mono: 187 mm x 115 mm x 78.5 mm
Weight	1500 g (including heatsink)

* Supported only on SW-16000TL-CXP4A

** TL model: when operated at linate rate 60kHz/25°C/PoCXP 25V Input

** Mono model: when operated at linate rate 277kHz/25°C/ PoCXP 25V Input

Dimensions

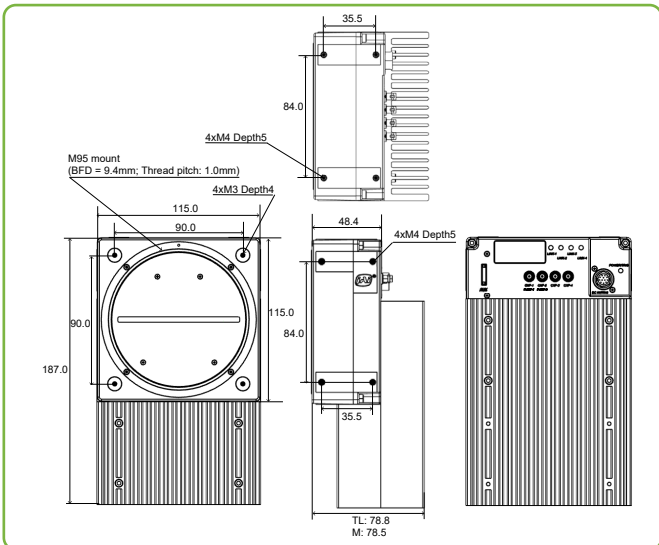

Spectral response

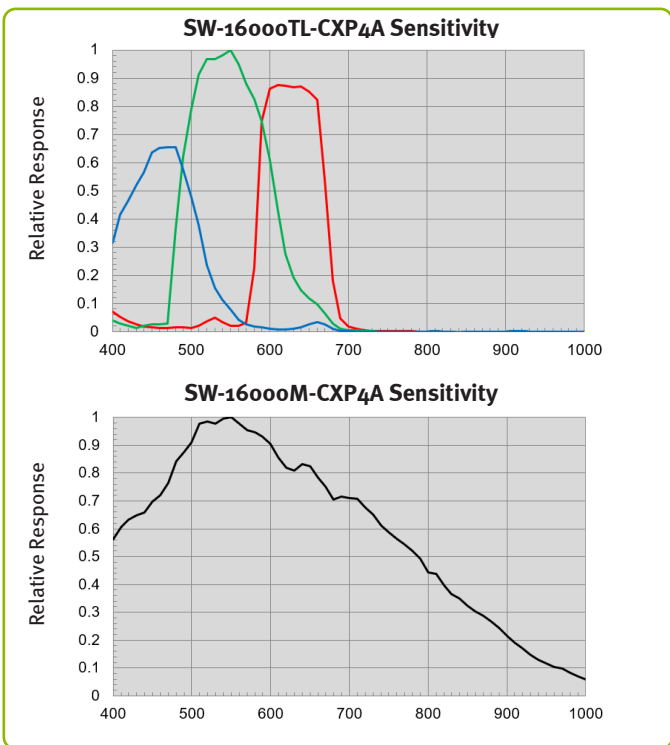

Connector pin-out

DC In / Trigger (12-pin)		AUX (10-pin)	
HR10A-10R-12PB(71)		Camera side: 3260-10S3 (55) Cable side: 3240-10P-C (50)	
Pin	Signal	Pin	Signal
1	Ground	1	TTL Out 2
2	DC in +12V to +24V	2	TTL Out 3
3	Ground	3	TTL In 2
4	TTL in 4	4	NC
5	Opto in 1-	5	Ground
6	Opto in 1+	6	TTL In 3
7	TTL out 4	7	NC
8	NC	8	NC
9	TTL out 1	9	Ground
10	TTL in 1	10	Ground
11	DC in +12V to +24 V		
12	Ground		

Ordering Information

SW-16000TL-CXP4A-M95	CMOS trilinear RGB line scan camera
SW-16000M-CXP4A-M95	CMOS monochrome lines scan camera

Europe, Middle East & Africa
Phone +45 4457 8888

Asia Pacific
Phone +81 45 440 0154

Americas
Phone +1 312 763 6570

