

■ 3 x 4096 pixels

■ 66 kHz

Sweep Series



❖ SW-4000TL-PMCL

High speed CMOS trilinear camera



- *Newly developed “state of the art” CMOS trilinear sensor*
- *Provides high speed 3 x 4096 pixel output at up to 66 kHz*
- *Horizontal and vertical binning functions*
- *Intelligent sub-pixel spatial compensation and tilted view correction*
- *HSI and XYZ color space conversion*
- *Large variety of trigger options*
- *Supports direct encoder connection to camera*
- *Excellent shock and vibration resistance*
- *Compact size and high robustness for industrial environments*
- *Time stamping of line data*
- *GenICam and Gen-CP-compliant Camera Link interface*
- *Supports Camera Link Base, Medium, Full, and Deca modes*

Specifications for SW-4000TL-PMCL

Sweep Series

Specifications	SW-4000TL-PMCL
Scanning system	Trilinear CMOS line scan
Active pixels	3 x 4096 pixels (R, G, B) in trilinear configuration
Line rate	Up to 65,963 kHz (variable)
Sensor width	30.72 mm
Pixel size	7.5 μm x 7.5 μm
Pixel clock (CL)	31.875 / 42.5 / 63.75 / 85 MHz
Video output	Camera Link Base (8 bit - RGB8) Camera Link Medium (8/10 bit - RGB8, RGB10) Camera Link Full (8 bit - RGB8) Camera Link Deca (8 bit - RGB8)
Object illuminance (min.)	220 lx @ 7800 K (Gain 18 dB, 525 μs exp., 50% video, RGB8)
Responsivity	127 DN/n/cm ² (G ch 10-bit @ 550 nm)
S/N ratio	57 dB on green, 10-bit with 0 dB gain
Inputs	Trigger (Camera Link, TTL/75Ω via 12-pin or 10-pin)
Outputs	LVAL, DVAL, EEN, XEEN (TTL)
Gain	Analog Base Gain: 0 dB / 6 dB / 12 dB Digital Master: 0 to +18 dB, R/B: -7.96 to +12 dB Digital Individual: 0 to +24 dB
Gamma	0.45 to 1.0 (9 steps) or 257-point LUT
Image processing	PRNU/DSNU, black level, shading, tilted view, spatial compensation, chromatic aberration
Color space conversion	RGB to HSI, RGB to XYZ (CIE), sRGB, Adobe RGB, or User Custom RGB
Exposure modes	No shutter, shutter select, and trigger width control
Electronic shutter	3 μs to 15.15 μs in 10 ns increments at fastest line rate. Exposure time can be longer at slower line rates.
Trigger width control	3 μs to 2 sec 1.8 μs to 1 sec (via 12-pin/10-pin connectors)
Control interface	Camera Link RS-232C
Lens mount	M42 ¹ mount or Nikon F-mount
Operating temp. (ambient)	-5°C to +45°C (20 to 80% non-condensing)
Storage temp. (ambient)	-25°C to +60°C (20 to 80% non condensing)
Vibration	10G (20 Hz to 200 Hz, XYZ directions)
Shock	80G
Regulations	CE (EN61000-6-2, EN61000-6-3) FCC Part 15 Class B, RoHS/WEEE, KC
Power	12-pin PoCL +12V to +24V DC ± 10% +10V DC to +13V DC
Power consumption	7.8 W typical @ +12V
Dimensions (H x W x L)	(without connector and lens mount protrusion) M42 mount 62 mm x 62 mm x 71.6 mm F-mount 62 mm x 62 mm x 71.8 mm
Weight	M42 mount 340 g F-mount 410 g

Ordering Information

SW-4000TL-PMCL-F	CMOS trilinear RGB camera with F-mount
SW-4000TL-PMCL-M42A	CMOS trilinear RGB camera with M42 ¹ mount

¹M42 x 1 with 16 mm flange back distance

Europe, Middle East & Africa Phone +45 4457 8888	Asia Pacific Phone +81 45 440 0154	Americas Phone +1 312 763 6570
---	---------------------------------------	-----------------------------------

Visit our website on www.jai.com

Dimensions (M42)

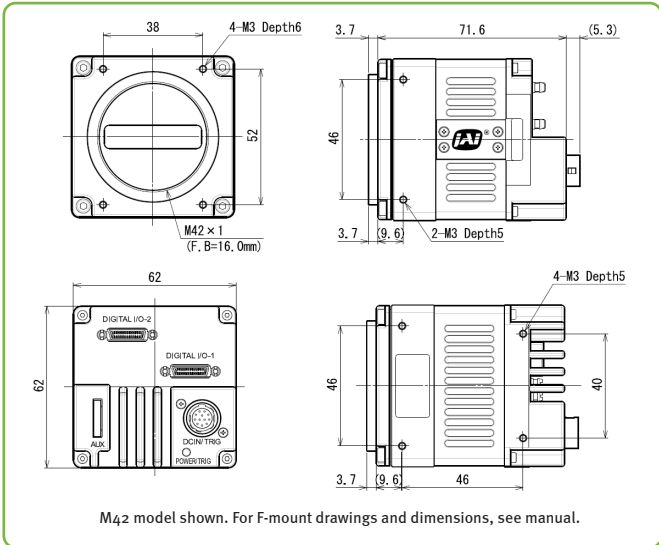

Connector pin-out

DC In / Trigger

HIROSE HR10A-10R-12PB(71)

Pin	Signal
1	Ground
2	DC in +12V to +24V
3	Ground
4	Reserved
5	Opto in 1-
6	Opto in 1+
7	TTL out 4
8	NC
9	TTL out 1
10	TTL in 1
11	DC in +12V to +24 V
12	Ground

Mini-CL Interface

Pin	Signal	Function
1	26	Power
2	15	X0-/X0+
3	16	X1-/X1+
4	17	X2-/X2+
5	18	Xclk-/Xclk+
6	19	X3-/X3+
7	20	SerTC-/SerTC-
8	21	SerTFG-/SerTFG+
9	22	CC1-/CC1+
10	23	CC2+/CC2-
11	24	CC3-/CC3+
12	25	CC4+/CC4-
13	14	ND

*Via Camera Link or 12-pin/10-pin connectors
Note: Camera Link Base configuration shown. For other configurations, refer to Camera Link specifications or operation manual.

Spectral response

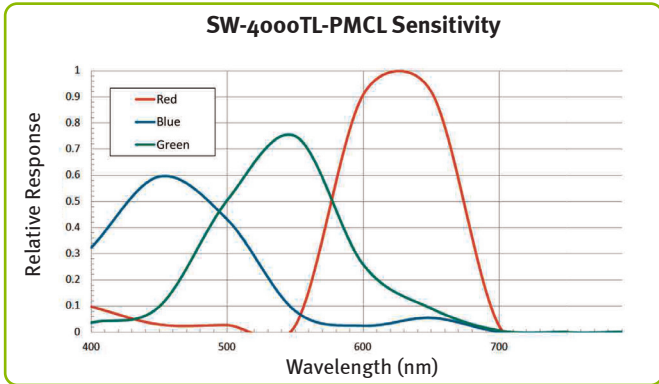

Company and product names mentioned in this datasheet are trademarks or registered trademarks of their respective owners. JAI A-S cannot be held responsible for any technical or typographical errors and reserves the right to make changes to products and documentation without prior notice.



See the possibilities